

Benefits

- Accurate and reliable in-line measurement of polymer slurry
- Minimizes need for sampling and laboratory analyses
- Ensures high-quality polymer production and optimized monomer conversion
- Increases productivity and minimizes residual

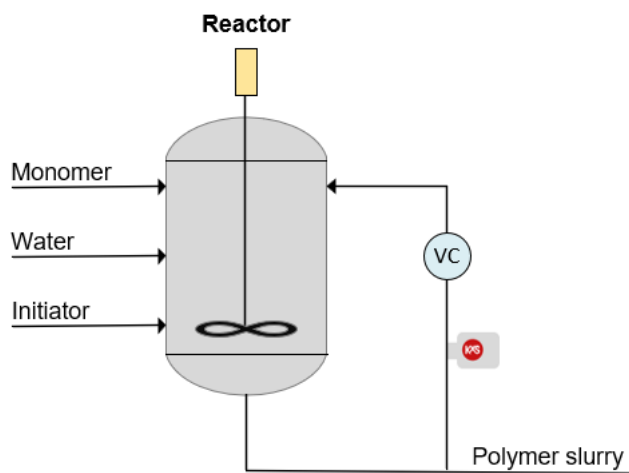

Overview

Polymers are macromolecules formed by linking small molecules called monomers through chemical reactions, a process known as polymerization. When the resulting polymer consists of two or more different monomers, the process is referred to as copolymerization.

Industrial polymerization is conducted using 4 primary methods: bulk, solution, suspension, emulsion, and gas-phase polymerization.

Controlling the polymerization process is critical as polymer properties are highly sensitive to operational conditions. Precise control ensures the production of high-quality specialty polymers tailored to specific applications and market requirements.

Refractive index measurement application

Polymerization typically occurs in stirred reactors as a solution. The reaction mixture usually includes a monomer, an initiator, and a liquid medium such as a solvent or water. Combining different monomers can enhance the final properties, producing advanced technical polymers.

The reaction begins with the addition of the initiator, transforming the initially non-viscous liquid monomer into a polymer solution, which increases in viscosity as polymerization progresses.

As the reaction continues, the monomer concentration decreases while the polymer concentration increases, altering the refractive index of the polymer slurry. The process continues until the desired conversion or degree of polymerization is achieved. At this point, additional ingredients may be added, or the reaction may be stopped.

Post-polymerization, the polymer slurry is removed from the vessel and subjected to further treatments such as distillation, condensation, filtration, or monomer recovery.

The polymerization reaction can occur at various temperatures and may take several hours, with the amount of reactants and reaction endpoint typically determined by the specific polymer recipe. Manufacturers producing multiple polymers or copolymers often have distinct recipes for each product based on the polymer's refractive index or viscosity.

Instrumentation and installation considerations

The KxS Process refractometer DCM-20 offers precise and reliable real-time refractive index measurement of the polymer slurry. Installed in-line in the bypass line of the reactor or directly at the bottom of the vessel through a steam jacket, the refractometer provides continuous measurement, reducing the need for sampling and laboratory analyses. This promotes

safer processing and increased productivity.

Real-time monitoring of refractive index changes allows close tracking of the polymerization reaction and degree of polymerization. The DCM-20 indicates when the target conversion and reaction endpoint are reached, enhancing monomer conversion and polymer productivity.

Additionally, the refractometer provides valuable insights into the reaction process, optimizing residence times and minimizing residual monomer and side-products. Excessive monomer or other components in the polymer slurry can negatively impact post-polymerization treatments and increase operational costs.

Traditional methods of monitoring polymerization, such as Gas Chromatography (GC) or laboratory tests, involve time-consuming sampling and analysis, with potential errors from solvent evaporation, sampling line variations, and subjective assessments.

In-line viscosity measurements are also common but can be sensitive to the concentration of charged initiator. For instance, an excess initiator can result in incomplete polymerization, where polymer chains remain too short for gelation.

The DCM-20 reliably measures all dissolved material in the polymer slurry, enabling early detection of issues and corrective action. Its output signal can facilitate automatic dilution of the



polymer product with water when necessary.

The refractometer is factory-calibrated for the full refractive index and temperature range, converting measured values directly to concentration units for the process medium. This conversion matches standard chemical curves or can be based on a refractive index set point.

Temperature variations are automatically compensated in the readings. Thanks to its unique 3-layer calibration method, the refractometer offers free interchangeability between applications or recipes without mechanical adjustments.

Maintenance-free and requiring no recalibration, the DCM-20's precise in-line refractive index measurement is crucial for controlling product quality and optimizing the process.

Chemical curve

Chemical curve for polymer slurry:
R.I. at reference temperature of 20°C

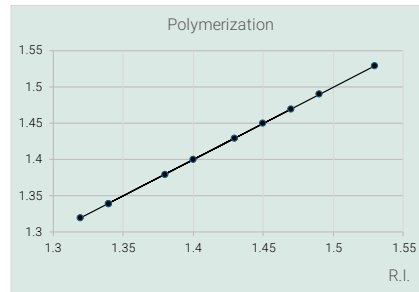

The refractive index curve shows a steady linear increase corresponding to the degree of polymerization. When the reaction achieves the endpoint the refractive index curve levels off.

Whereas the density measurement cannot indicate the difference between monomers and polymer nor detect the polymerization degree.